

Reg. No.

--	--	--	--	--	--	--	--	--	--	--	--	--	--	--	--	--	--	--	--

Question Paper Code : 51643

~~MECH~~
MECH

B.E./B.Tech. DEGREE EXAMINATION, MAY/JUNE 2016

First Semester

Civil Engineering

GE 2111/ME 15 – ENGINEERING GRAPHICS

(Common to all Branches)

(Regulations 2008)

Time : Three Hours

Maximum : 100 Marks

Answer ALL questions.

(5 × 20 = 100 Marks)

1. (a) Draw the hyperbola with the distance between its focus and directrix equal to 75 mm and the eccentricity equal to 1.5. Draw a normal and a tangent to the curve at a point P on the curve, 65 mm from the face. (20)

OR

- (b) Draw by freehand the front view, top view and side view of the object shown below : (20)

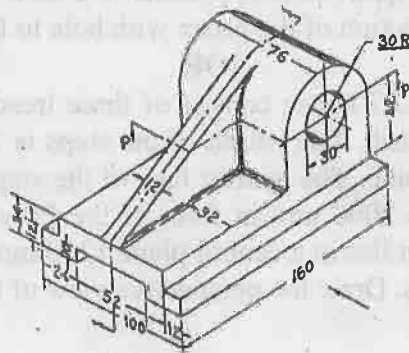

2. (a) The projections on the XY line of the horizontal and vertical traces of a straight line AB in the first quadrant are 120 mm apart. The vertical trace is 100 mm above XY and horizontal trace 50 mm in front of XY line. The points A and B are 30 mm and 80 mm above the horizontal plane respectively. Draw the projections. (20)

OR

- (b) A hexagonal lamina of 30 mm side rests on one of its corners on the HP. The diagonal passing through this corner is inclined at 45° to the HP. Draw three view of the lamina. (20)

3. (a) A square prism of base side 30 mm and axis 70 mm rests on HP on one of its longer edges with the rectangular faces equally inclined to HP. The axis is inclined at 30° to VP. Draw the top and front views of the prism. (20)

OR

- (b) Draw the projections of a right circular cone of base diameter 60 mm and altitude 80 mm lying on HP with one of its generators. The axis is parallel to VP. (20)

4. (a) A vertical cylinder 40 mm diameter is cut by a vertical section plane making 30° to VP in such a way that the true shape of the section is a rectangle of 25 mm and 60 mm sides. Draw the projections and true shape of the section. (20)

OR

- (b) A rectangular pyramid 60 mm \times 50 mm and height 75 mm is resting on its base on HP with its longer base edges parallel to VP. It is sectioned by a plane perpendicular to VP, inclined at 65° to HP and passing through the mid-point of the axis. Develop the lateral surfaces of the cut pyramid. (20)

5. (a) A hexagonal prism of base side 20 mm and height 40 mm has a square hole of side 16 mm at the centre. The axes of the square and hexagon at prism coincide. One of the faces of the square hole is parallel to a face of the hexagon at prism. Draw the isometric projection of the prism with hole to full scale. (20)

OR

- (b) Steps provided for an LIG house consist of three treads of 250 mm each and three rises of 150 mm each. The length of the steps is 1000 mm. The steps are parallel to the picture plane. The nearest face of the steps is 500 mm behind the PP. The station point is 2000 mm in front of the PP and 1000 mm above the ground. The station point lies in a central plane 1250 mm to the right of the right extreme face of the steps. Draw the perspective view of the steps. (20)